

COMBI

740

- Gate operator "ALL-IN-ONE"
- Fully concealed
- Underground
- Automatic

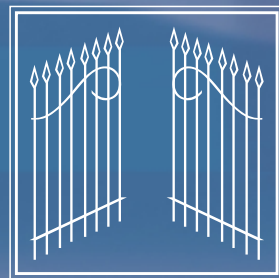

FADINI[®]
the gate opener

COMBI 740

Gate operator "ALL-IN-ONE" Fully concealed Underground Automatic

The gate operator **COMBI 740** is to be installed at the foot of the gate perpendicular to the center line of the gate hinges.

The working mechanism is fully concealed under the ground. The all-in-one design makes this unit easy and quick to install. The motor-pump and the jack are in the same enclosure, no tubes outside and no need to fill with oil as the unit is supplied ready to work and factory pre-oiled. Once the enclosure is set with concrete, you only need to fix the mechanism in it, which is simple because the enclosure is designed ready to take the combined unit. Instructions are provided to set the enclosure correctly, so that its upper flange is perfectly horizontal with the pavement finish level.

The COMBI 740 units are right- or left-handed. There are marks to identify them: D for right-handed and S for left-handed. The motor pump unit is fitted with pressure valves which ensure anti-crush safety. Being fully buried under the gate, the valves are safe from misuse and vandalism. On the other hand they are located in an ideal position for setting operations during installation. The two-way locking device is incorporated in the valve assembly, in the oil circuit. It becomes operative when the electric motor stops, and firmly holds the gates in any required position in the open or close cycles.

The shaft is made of treated steel, and has a fitting end to match a square bush. This has very high mechanical strength, so it can perform to its utmost, regardless of the gate weight it is required to support, also the torsion stress and possible overloading during manual operations of the gate. On request

there is available a model where the jack is fitted with a dampening device, which slows down the gate speed on approaching end stroke in open and close cycles.

Also on request a non locking model is available, for cases where it is advisable to install an electric lock on the gate.

The unit is pre-wired. The electric cable is water-proof and is connected to the electric motor through a special gland providing perfect sealing.

A special sleeve ensures suitable insulation, long life and resistance to sudden temperature changes. The cable is made up of four wires, three for the mains and one for the earth connection. They are different in colour for easy identification.

The equipment is automatically operated by means of a programmable, highly reliable control panel set to perform the required operations.

A mechanical releasing device completes COMBI 740 locking type and allows the gates to be manually operated in events like

power failure. This device fits between the bottom edge of the gate and the operator shaft, as shown in the picture.

A key is supplied to release the two component parts so that the gates can be pushed open and close. A stainless steel cover can be supplied on request to be screwed down to the standard cover for a high grade finish.

Like all the other operators in the Fadini product range, this underground system of new construction principles has been entirely developed by Meccanica Fadini and is the result of many years' research, study and tests aimed to achieve quality and long lasting reliability.



- (A) Emergency locking shoe, released
- (B) Equipment in working condition
- (C) **COMBI 740** on site application. Gate stop in open gate position.
- (D) Post with photocell for safety



(A)



(B)



(C)



(D)

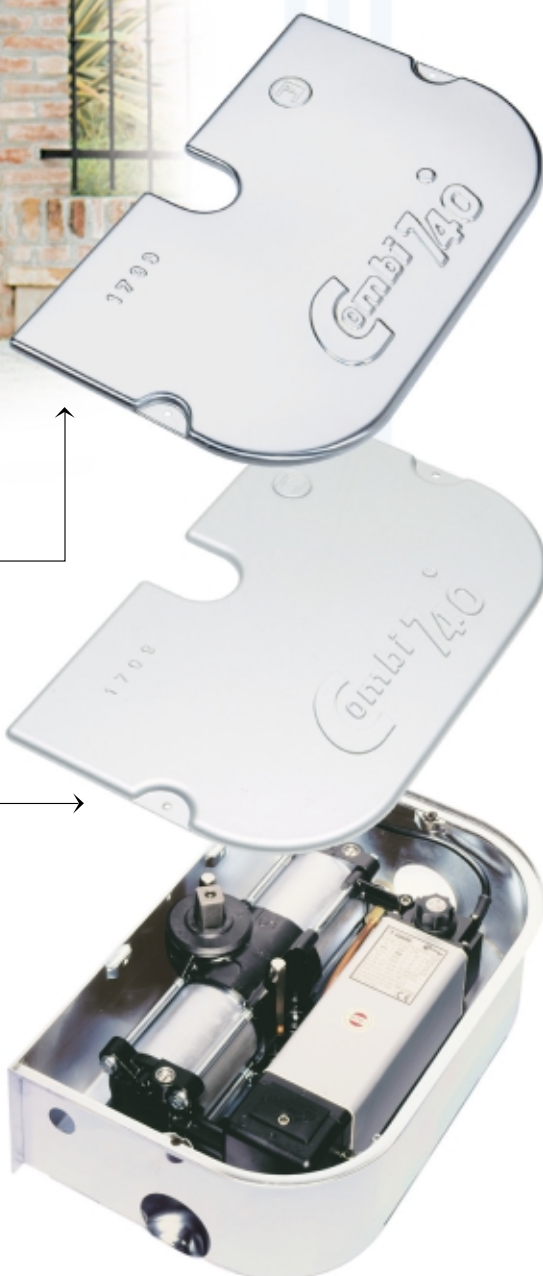

OPTIONAL
Stainless steel cover

Standard
aluminium cover

Enclosure

COMBI 740 GATE OPERATOR

Technical specifications

CLASS H, TWO-PHASE, ELECTRIC MOTOR

Power output	0.18 KW (0.25 HP)
Supply voltage	230 V - 50 Hz
Absorbed current	1.2 A
Absorbed power	250 W
Capacitor	12.5 µF
Motor rotation speed.....	1'350 rpm
Intermittent service.....	S 3

DOUBLE STROKE JACK AND OIL-HYDRAULIC PUMP

Pump flow rate-P3	0.85 l/min.
Working pressure	1 MPa (10 bars)
Max. pressure	3 MPa (30 bars)
Working temperature.....	-20°C +80°C
Rotation time (110°).....	23 s
Type of oil	A 15 FADINI by AGIP
Shaft rotation angle	110°
Rated torque.....	137.3 Nm
Cylinder bore	75 mm
Stroke	52 mm
Weight with accessories	27 Kg
IP Standards	IP 673
Static gate weight	700 Kg
Overall dimensions (LxWxH).....	470x300x150 mm
Duty cycle.....	23 sec. Open - 30 sec. Dwell - 23 sec. Close
Time of one complete cycle.....	76 s
No. of complete cycles: Open - Dwell - Close	47/hour
No. of cycles a year, 8 hours a day.....	137'000

DAMPENING

Pump flow rate - P3	0.85 l/min.
Rotation time (175°).....	28 s

PRODUCT FEATURES

- Pre-oiled and pre-set for immediate installation.
- Close proximity of pump and jack gives fast response.
- Close pivot point (45 mm) to gate pier.
- Manual release from inside and outside of property.
- Choice of 110° or 175° rotation angle.
- Braking or non-braking versions available.
- Locking or non-locking versions available.
- Conforming to EN 12445, EN 12453 safety standards.
- All-in-one pump and jack unit, contained in a single enclosure, is sunk into the ground at the foot of the left-hand and right-hand gate to achieve synchronised operation. The unit should be piped into a soak-away to allow for water drainage.

WARNINGS

- Should the combined unit jack/hydraulic motor pump be removed for maintenance, servicing or repair, disconnect the electric motor cable from the junction box.
- Never cut off the cable from the electric motor.
- Make sure that the oil plug is properly tightened.
- Do not throw away oil from repaired or serviced units, waste oil must be disposed of properly through a specialised company.
- Do not throw away packaging such as cardboard, polystyrene and nylon, which must be disposed of properly through a specialised company.
- The electrical equipment must be properly earthed.

Distributor's box

The manufacturers reserve the right to change the products without any previous notice

Accessories



ELPRO 13 CEI
electronic programmer



EDI 60
digital keypad



PRIT 19
keyswitch



MIRI 4
flashing lamp



BIRIO A8
aerial



POLO 44
photocells



ASTRO 43/1 R
radio



ASTRO 43/2 TR
transmitter

LEFT-HANDED UNIT - VIEW FROM INSIDE PROPERTY

Suitable for gate width from 2 up to 3.5 m max. with or without locking/dampening depending on gate size and site requirements

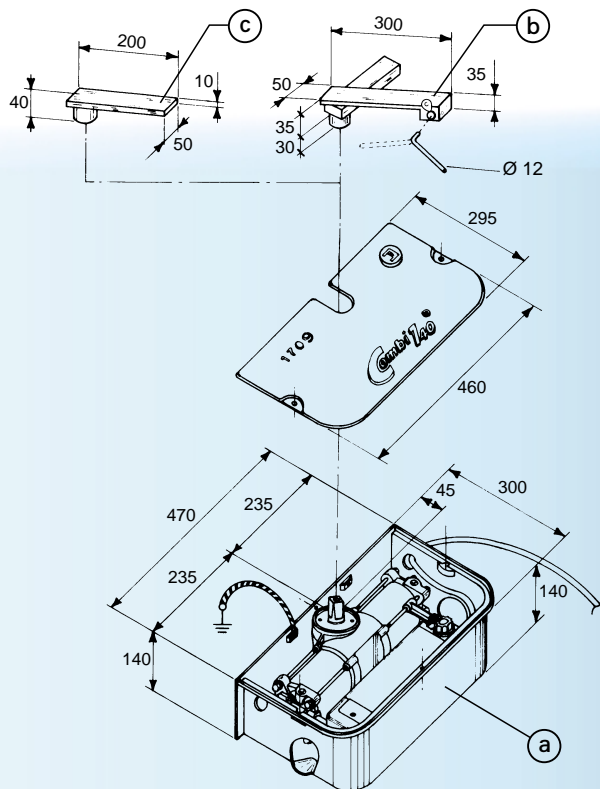

(a)

The combined motor and jack of the **COMBI 740** employs the latest technology with a quiet-running steel lobe pump at its heart, creating and holding greater pressures for hydraulic locking and drive than most other underground gate operators.

(b)

Gate fixing device (locking version) is welded or screwed to gate foot. Lock can be released by special key.

(c)

Gate fixing device (non-locking version) is welded to gate foot.

(d)

Fix to the ground proper **gate stops** both in the open and close gate position.
See p. 7 in the installation manual.



EUROPEAN MARK CERTIFYING CONFORMITY TO THE ESSENTIAL REQUIREMENTS OF THE STANDARDS 98/37/EC

- DECLARATION OF CONFORMITY
- GENERAL WARNINGS
- EN 12445, EN 12453 STANDARDS
- CEI EN 60204-1 STANDARDS
- WARRANTY CERTIFICATE ON THE CUSTOMER'S REQUEST

The "CE" mark certifies that the operator conforms to the essential requirements of the European Directive art. 10 EEG 73/23, in relation to the manufacturer's declaration for the supplied items, in compliance with the body of the regulations ISO 9000=UNI EN 29000. Automation in conformity to EN 12445, EN 12453 safety standards. The growth of MECCANICA FADINI has always been based on the development of guaranteed products thanks to our "TOTAL QUALITY CONTROL" system which ensures constant quality standards, updated knowledge of the European Standards and compliance with their requirements, in view of an ever increasing process of improvement.



AUTOMATIC GATE MANUFACTURERS

Via Mantova, 177/A - 37053 Cerea (Verona) Italy - Tel. 0442 330422 r.a. - Fax 0442 331054 - e-mail: info@fadini.net - www.fadini.net